

# Bremsen mit Hohlwelle *Through Shaft Brakes*

## FAT 350 FAT 350 RR\*

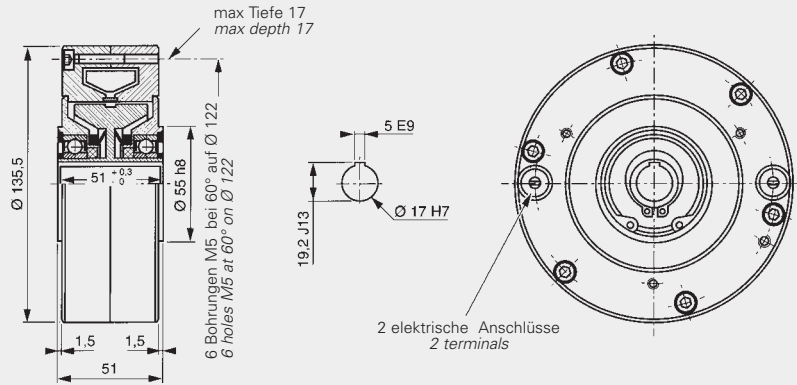

## FRAT 350 FRAT 350 RR\*

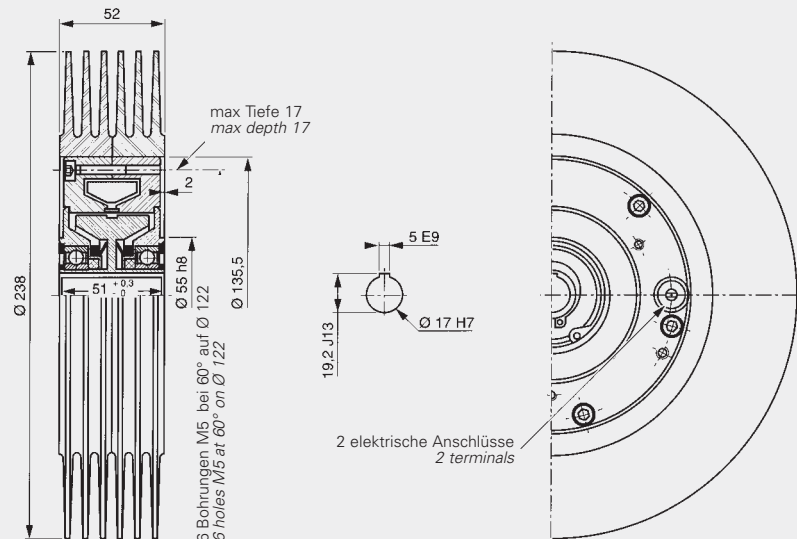

**\*RR** Die so bezeichnete baugleiche Einheit ist mit remanentem Rotor ausgerüstet. Dies bedeutet, dass Drehzahlen ab 40 min<sup>-1</sup> möglich sind und der Einbau mit vertikaler Achse erfolgen kann.

The so defined identically constructed unit is executed with a remanent rotor. This means that a speed from 40 rpm is possible and the installation can be done with vertical axis.

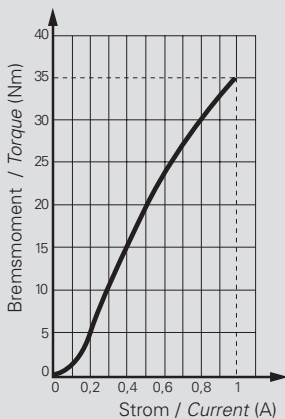

### Technische Daten *Specifications*

			FAT 350	FRAT 350
Nennmoment	<i>Nominal torque</i>	(Nm)	35	35
Kleinstes Moment	<i>Minimal torque</i>	(Nm)	0,33	0,33
* Kleinstes Moment RR	<i>Minimal torque RR</i>	(Nm)	0,66	0,66
Spulenwiderstand	<i>Coil resistance</i>	(Ω)	19	19
Gleichstrom/Nennwert	<i>Rated current DC</i>	(A)	1	1
Trägheitsmoment Rotorgewicht	<i>Rotor inertia</i>	(kg·m <sup>2</sup> )	0,79·10 <sup>-3</sup>	0,79·10 <sup>-3</sup>
Minimale Drehzahl	<i>Min rotation speed</i>	(min <sup>-1</sup> /rpm)	60	60
Maximale Drehzahl	<i>Max rotation speed</i>	(min <sup>-1</sup> /rpm)	3000	3000
Maximale Außentemperatur im Dauerbetrieb	<i>Rated outside body temperature</i>	(°C)	90	90
Höchstzulässige kurzzeitige Betriebstemperatur	<i>Ultimate outside body temperature</i>	(°C)	110	110
Einschaltzeit/Nennmoment	<i>Switch-on time/nominal torque</i>	(ms)	400	400
Ausschaltzeit/Restmoment	<i>Switch-off time/min. torque</i>	(ms)	320	320
Gewicht	<i>Weight</i>	(kg)	4,6	6,8
Wärme-Verlustleistung 100% Betrieb	<i>Heat dissipation continuous sustained</i>	(W)	100	210

# Bremsen mit Hohlwelle *Through Shaft Brakes*

## FVAT 350 FVRAT 350



FVAT 350  
(mit Axiallüfter) 24 V DC  
(with axial fan) 24 V DC

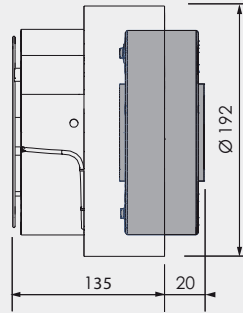

FVRAT 350  
(mit Radiallüfter) 230 V AC  
(with radial fan) 230 V AC

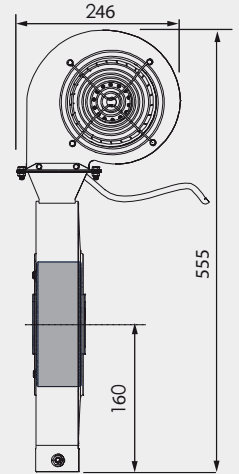

## FRATO 350

mit Wasserkühlung  
with water cooling unit

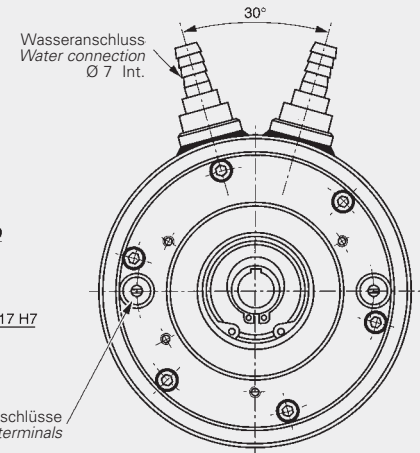
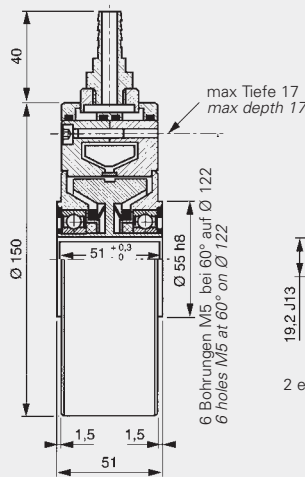

Wasserdurchfluss	water flow requirement	l/h	100
Wassertemperatur	water temperature	°C	18 - 40
Wasserdruck max.	water pressure max.	Bar	2,5

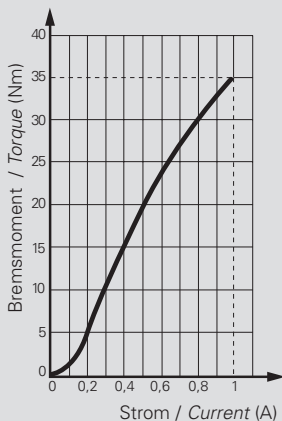

Technische Daten	Specifications	FVAT 350	FVRAT 350	FRATO 350
Nennmoment	Nominal torque	(Nm) 35	35	35
Kleinstes Moment	Minimal torque	(Nm) 0,33	0,33	0,33
* Kleinstes Moment RR	Minimal torque RR	(Nm) 0,66	0,66	0,66
Spulenwiderstand	Coil resistance	(Ω) 19	19	19
Gleichstrom/Nennwert	Rated current DC	(A) 1	1	1
Trägheitsmoment Rotorgewicht	Rotor inertia	(kg·m²) 0,79·10 <sup>-3</sup>	0,79·10 <sup>-3</sup>	0,79·10 <sup>-3</sup>
Minimale Drehzahl	Min rotation speed	(min <sup>-1</sup> /rpm) 60	60	60
Maximale Drehzahl	Max rotation speed	(min <sup>-1</sup> /rpm) 3000	3000	3000
Maximale Außentemperatur im Dauerbetrieb	Rated outside body temperature	(°C) 90	90	90
Höchstzulässige kurzzeitige Betriebstemperatur	Ultimate outside body temperature	(°C) 110	110	110
Einschaltzeit/Nennmoment	Switch-on time/nominal torque	(ms) 400	400	400
Ausschaltzeit/Restmoment	Switch-off time/min. torque	(ms) 320	320	320
Gewicht	Weight	(kg) 5,8	11,7	5,4
Wärme-Verlustleistung 100% Betrieb	Heat dissipation continuous sustained	(W) 500	1400	1600