

FVAT 1200 FVRAT 1200

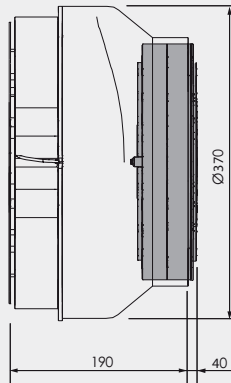

FVAT 1200
(mit Axiallüfter) 24 V DC
(with axial fan) 24 V DC



FVRAT 1200
(mit Radiallüfter) 230 V AC
(with radial fan) 230 V AC

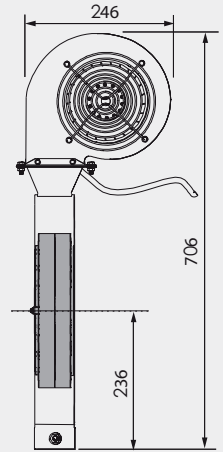

VR 1200/2002 Radiallüfter *Radial Fan Cooling Unit*

Anwendung
Diese Kühleinheit wird mit drei Schrauben M6x16 DIN 912 und Ø6 Unterlegscheiben zur Befestigung am Bremsenkühler ausgeliefert.
Utilization
This cooling unit is delivered with three screws M6x16 DIN 912 and Ø6 washers to be fixed on the brake's heater.

Technische Daten / Specifications

| | | | |
|-------------|------------------|-------|------|
| Spannung | Voltage | (V) | 230 |
| Frequenz | Frequency | (Hz) | 50 |
| Leistung | Power | (W) | 242 |
| Gewicht | Weight | (kg) | 5,5 |
| Stromstärke | Amperage | (Amp) | 1,1 |
| Lautstärke | Sound Level | (dBa) | 67 |
| Absicherung | Protection Level | | IP44 |

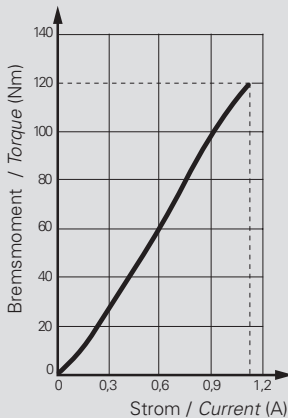
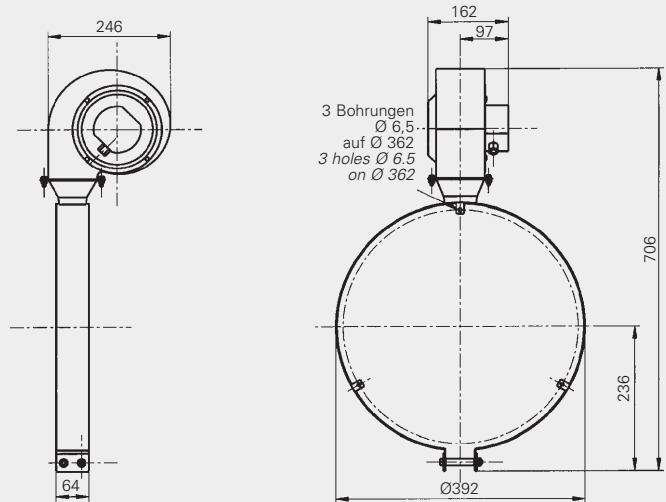

Technische Daten Specifications

| | | | FVAT 1200 | FVRAT 1200 |
|---|--|--------------------------|-----------------------|-----------------------|
| Nennmoment | Nominal torque | (Nm) | 120 | 120 |
| Kleinstes Moment | Minimal torque | (Nm) | 1,20 | 1,20 |
| * Kleinstes Moment RR | Minimal torque RR | (Nm) | 2,40 | 2,40 |
| Spulenwiderstand | Coil resistance | (Ω) | 12,50 | 12,50 |
| Gleichstrom/Nennwert | Rated current DC | (A) | 1,10 | 1,10 |
| Trägheitsmoment Rotorgewicht | Rotor inertia | (kg·m ²) | 26,5·10 ⁻³ | 26,5·10 ⁻³ |
| Minimale Drehzahl | Min rotation speed | (min ⁻¹ /rpm) | 60 | 60 |
| Maximale Drehzahl | Max rotation speed | (min ⁻¹ /rpm) | 2000 | 2000 |
| Maximale Außentemperatur im Dauerbetrieb | Rated outside body temperature | (°C) | 90 | 90 |
| Höchstzulässige kurzzeitige Betriebstemperatur | Ultimate outside body temperature | (°C) | 110 | 110 |
| Einschaltzeit/Nennmoment | Switch-on time/nominal torque | (ms) | 760 | 760 |
| Ausschaltzeit/Restmoment | Switch-off time/min. torque | (ms) | 685 | 685 |
| Gewicht | Weight | (kg) | 28,0 | 30,5 |
| Wärme-Verlustleistung 100% Betrieb | Heat dissipation continuous sustained | (W) | 1400 | 2000 |