

# Bremsen mit Hohlwelle *Through Shaft Brakes*

## FVAT 2002 FVRAT 2002

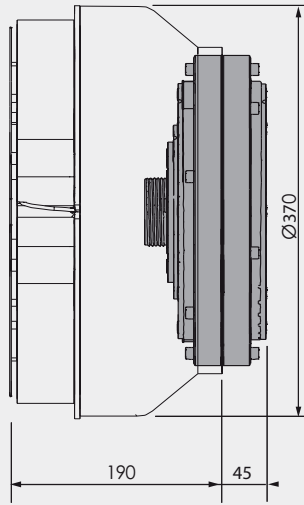

FVAT 2002  
(mit Axiallüfter) 24 V DC  
(with axial fan) 24 V DC



FVRAT 2002  
(mit Radiallüfter) 230 V AC  
(with radial fan) 230 V AC

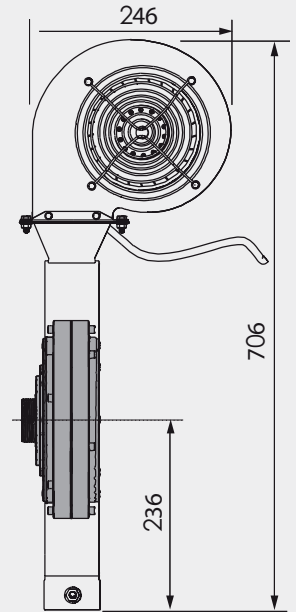

## FRATO 2002

mit Wasserkühlung  
*with water cooling unit*

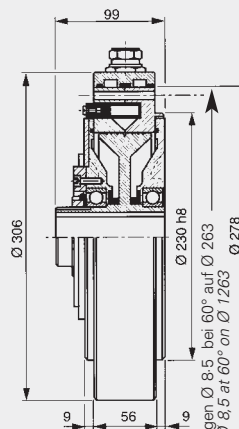

6 Bohrungen Ø 8,5 bei 60° auf Ø 263  
6 holes Ø 8,5 at 60° on Ø 263

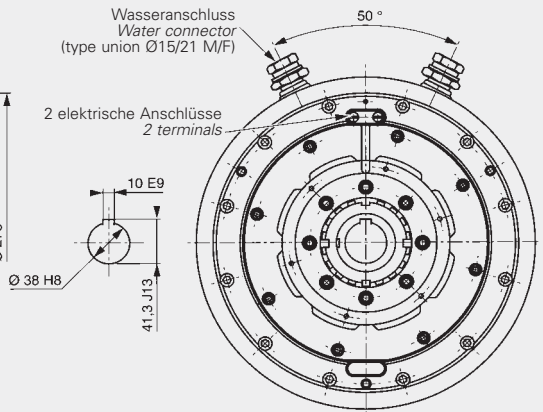

Wasserdurchfluss	<i>water flow requirement</i>	l/h	120
Wassertemperatur	<i>water temperature</i>	°C	18 - 40
Wasserdruck max.	<i>water pressure max.</i>	Bar	2,5

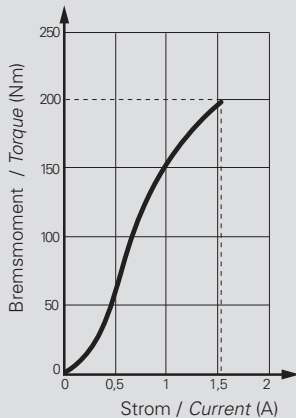

Technische Daten	Specifications		FVAT 2002	FVRAT 2002	FRATO 2002
Nennmoment	<i>Nominal torque</i>	(Nm)	200	200	200
Kleinstes Moment	<i>Minimal torque</i>	(Nm)	2	2	2
* Kleinstes Moment RR	<i>Minimal torque RR</i>	(Nm)	4	4	4
Spulenwiderstand	<i>Coil resistance</i>	(Ω)	11	11	11
Gleichstrom/Nennwert	<i>Rated current DC</i>	(A)	1,55	1,55	1,55
Trägheitsmoment Rotorgewicht	<i>Rotor inertia</i>	(kg·m <sup>2</sup> )	35,2·10 <sup>-3</sup>	35,2·10 <sup>-3</sup>	35,2·10 <sup>-3</sup>
Minimale Drehzahl	<i>Min rotation speed</i>	(min <sup>-1</sup> /rpm)	60	60	60
Maximale Drehzahl	<i>Max rotation speed</i>	(min <sup>-1</sup> /rpm)	2000	2000	2000
Maximale Außentemperatur im Dauerbetrieb	<i>Rated outside body temperature</i>	(°C)	90	90	90
Höchstzulässige kurzzeitige Betriebstemperatur	<i>Ultimate outside body temperature</i>	(°C)	110	110	110
Einschaltzeit/Nennmoment	<i>Switch-on time/nominal torque</i>	(ms)	1100	1100	1100
Ausschaltzeit/Restmoment	<i>Switch-off time/min. torque</i>	(ms)	1000	1000	1000
Gewicht	<i>Weight</i>	(kg)	34,5	35,5	28,0
Wärme-Verlustleistung 100% Betrieb	<i>Heat dissipation continuous sustained</i>	(W)	1800	2000	2500