

FVRAT 10001

mit Radiallüfter 230 V AC
with radial fan 230 V AC

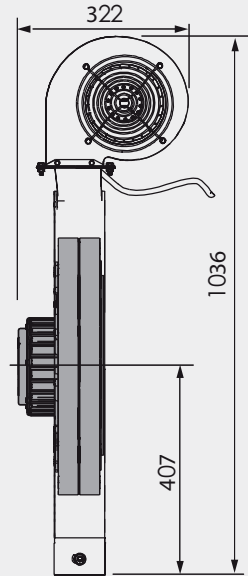
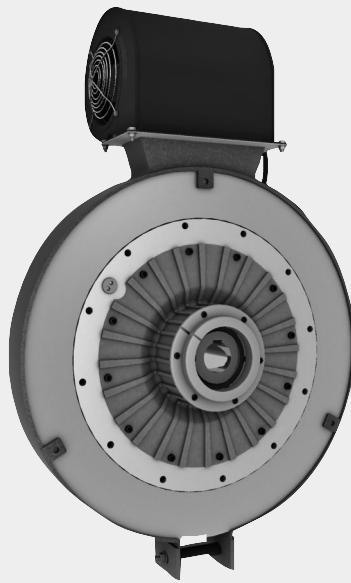

VR 10001 Radiallüfter *Radial Fan Cooling Unit*

Anwendung

Diese Kühleinheit wird mit drei Schrauben M6x16
DIN 912 und Ø6 Unterlegscheiben zur Befestigung am
Bremsenkühler ausgeliefert.

Utilization

This cooling unit is delivered with three screws M6x16
DIN 912 and Ø6 washers to be fixed on the brake's heater.

Technische Daten / Specifications

Spannung	Voltage	(V)	230
Frequenz	Frequency	(Hz)	50
Leistung	Power	(W)	242
Gewicht	Weight	(kg)	8,5
Stromstärke	Amperage	(Amp)	1,1
Lautstärke	Sound Level	(dBA)	67
Absicherung	Protection Level		IP44

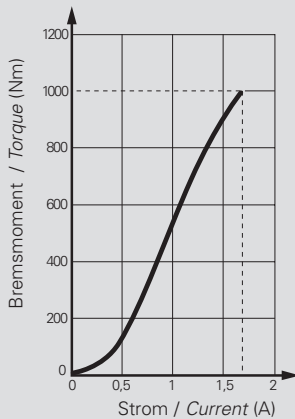
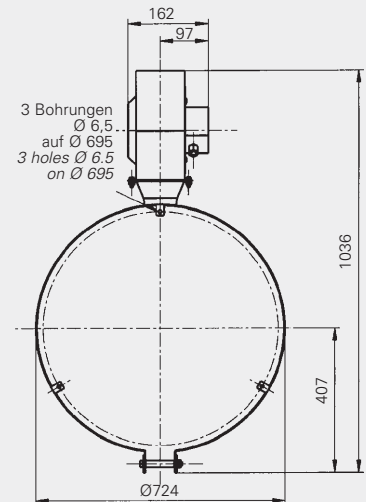
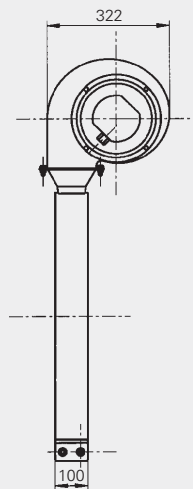

Technische Daten

Specifications

FVRAT 10001

Nennmoment	Nominal torque	(Nm)	1000
Kleinstes Moment	Minimal torque	(Nm)	10
* Kleinstes Moment RR	Minimal torque RR	(Nm)	20
Spulenwiderstand	Coil resistance	(Ω)	20
Gleichstrom/Nennwert	Rated current DC	(A)	1,70
Trägheitsmoment Rotorgewicht	Rotor inertia	(kg·m ²)	809·10 ⁻³
Minimale Drehzahl	Min rotation speed	(min ⁻³ /rpm)	60
Maximale Drehzahl	Max rotation speed	(min ⁻³ /rpm)	1000
Maximale Außentemperatur im Dauerbetrieb	Rated outside body temperature	(°C)	90
Höchstzulässige kurzzeitige Betriebstemperatur	Ultimate outside body temperature	(°C)	110
Einschaltzeit/Nennmoment	Switch-on time/nominal torque	(ms)	5000
Ausschaltzeit/Restmoment	Switch-off time/min. torque	(ms)	4600
Gewicht	Weight	(kg)	143,0
Wärme-Verlustleistung 100% Betrieb	Heat dissipation continuous sustained	(W)	7000