

# MTD-1

## MTD-1-SW

Maße für SW-Ausführung in Klammern  
 SW-Dimensions in brackets

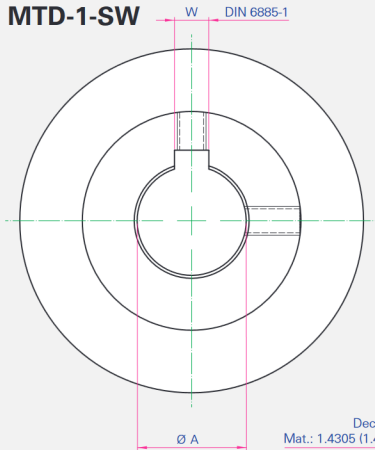

Deckel / Cover  
 Mat.: 1.4305 (1.4401@SW)

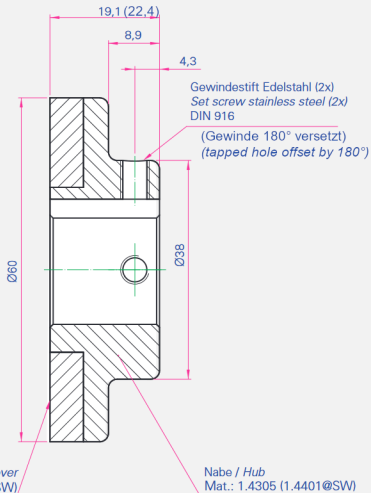

## Technische Daten

### Technical Specifications

Typ Type	Borung Bore Ø A (mm)	Passfeder Keyway W (mm)	Gewindestift Set Screw
<b>MTD-1-8</b>	8H7	2	M5
<b>MTD-1-10</b>	10H7	3	M5
<b>MTD-1-12</b>	12H7	4	M5
<b>MTD-1-14</b>	14H7	5	M5
<b>MTD-1-16</b>	16H7	5	M5
<b>MTD-1-18</b>	18H7	6	M5
<b>MTD-1-19</b>	19H7	6	M5

Typ Type	Max. Geschw Speed (rpm)	Gewicht pro Hälfte Weight per Hub (kg)
<b>MTD-1</b>	19000	0,3