

MTD-50

MTD-50-SW

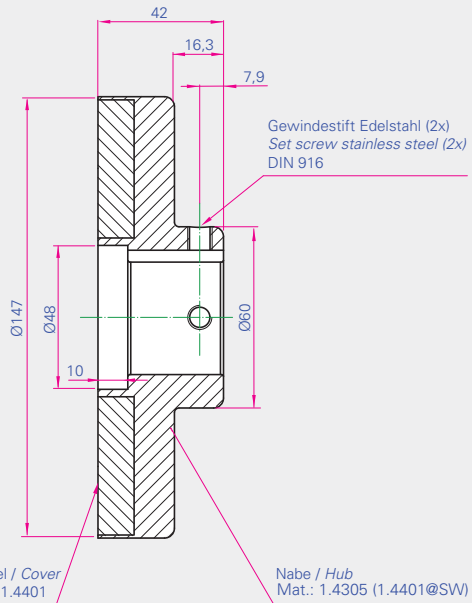
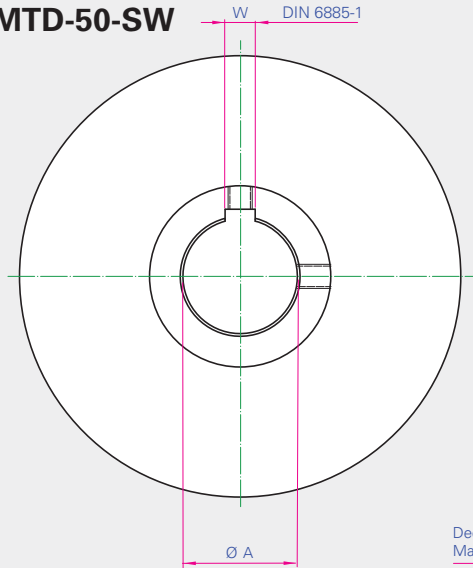

Technische Daten Technical Specifications

Typ Type	Max. Geschw Speed (rpm)	Gewicht pro Hälfte Weight per Hub (kg)
MTD-400	7800	3,1

Typ Type	Bohrung Bore $\varnothing A$ (mm)	Passfeder Keyway W (mm)	Gewindestift Set Screw
MTD-50-25	25H7	8	M8
MTD-50-30	30H7	8	M8
MTD-50-35	35H7	10	M8
MTD-50-38	38H7	10	M8